

VALUSEAL SEALED CONNECTOR SYSTEM

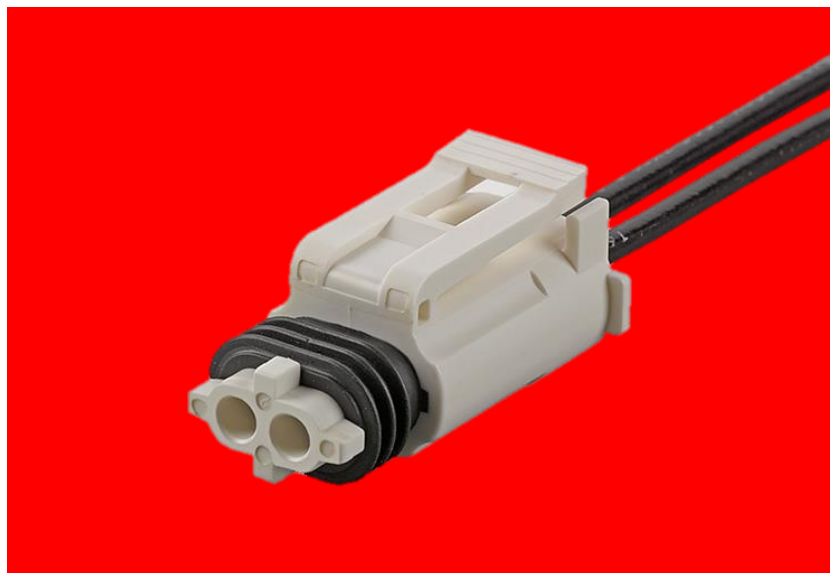

WIRE TO WIRE – 1x2 CKT

REVISION: A2	ECR/ECN INFORMATION: EC No: 167947 DATE: 10/11/2017	TITLE: Application specification Valuseal sealed connector system	SHEET No. 1 of 16
DOCUMENT NUMBER: 1728770001-AS	CREATED / REVISED BY: Muttanna B	CHECKED BY: Muttanna B	APPROVED BY: ISHWAR G

SCOPE

This specification covers the requirements for the application of Valuseal wire to wire sealed connector system.

TABLE OF CONTENTS

- Section 1: Product Introduction
- Section 2: Product Summary
- Section 3: Plug connector Assembly
- Section 4: Receptacle connector Assembly
- Section 5: Cavity plug Assembly
- Section 6: WTW Connector Assembly
- Section 7: Service Instructions
- Section 8: Connector/Cable Clamping
- Section 9: General application notes

Section 1: Product Introduction

Product Description	Series number
Plug Housing with Integrated seal	172877
Receptacle Housing with Integrated seal	172878
Male crimp terminal	173041
Female crimp terminal	173042
Void plug	173061

REVISION: A2	ECR/ECN INFORMATION: EC No: 167947 DATE: 10/11/2017	TITLE: Application specification Valuseal sealed connector system	SHEET No. 2 of 16
DOCUMENT NUMBER: 1728770001-AS	CREATED / REVISED BY: Muttanna B	CHECKED BY: Muttanna B	APPROVED BY: ISHWAR G

Section 2: Product Summary

1. Plug assembly details

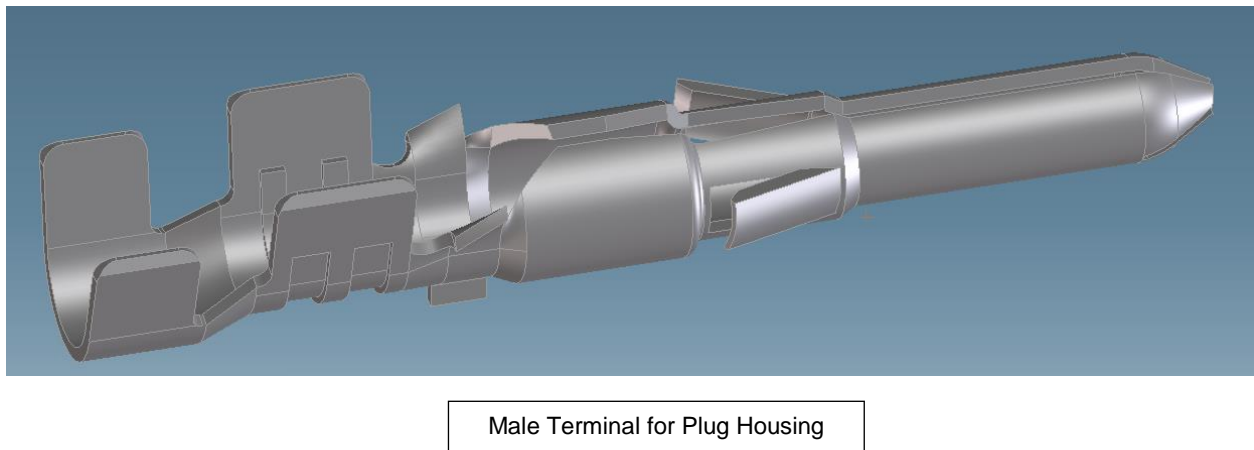
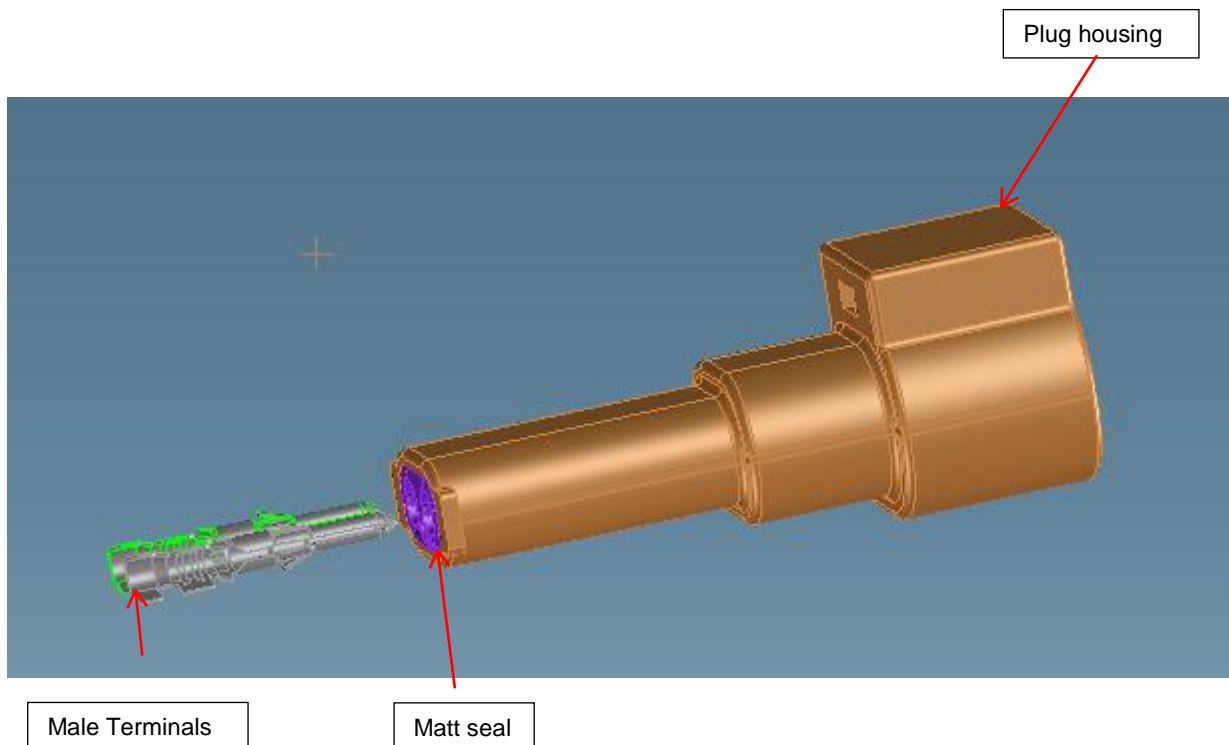

REVISION: A2	ECR/ECN INFORMATION: EC No: 167947 DATE: 10/11/2017	TITLE: Application specification Valuseal sealed connector system	SHEET No. 3 of 16
DOCUMENT NUMBER: 1728770001-AS	CREATED / REVISED BY: Muttanna B	CHECKED BY: Muttanna B	APPROVED BY: ISHWAR G

2. Receptacle assembly details

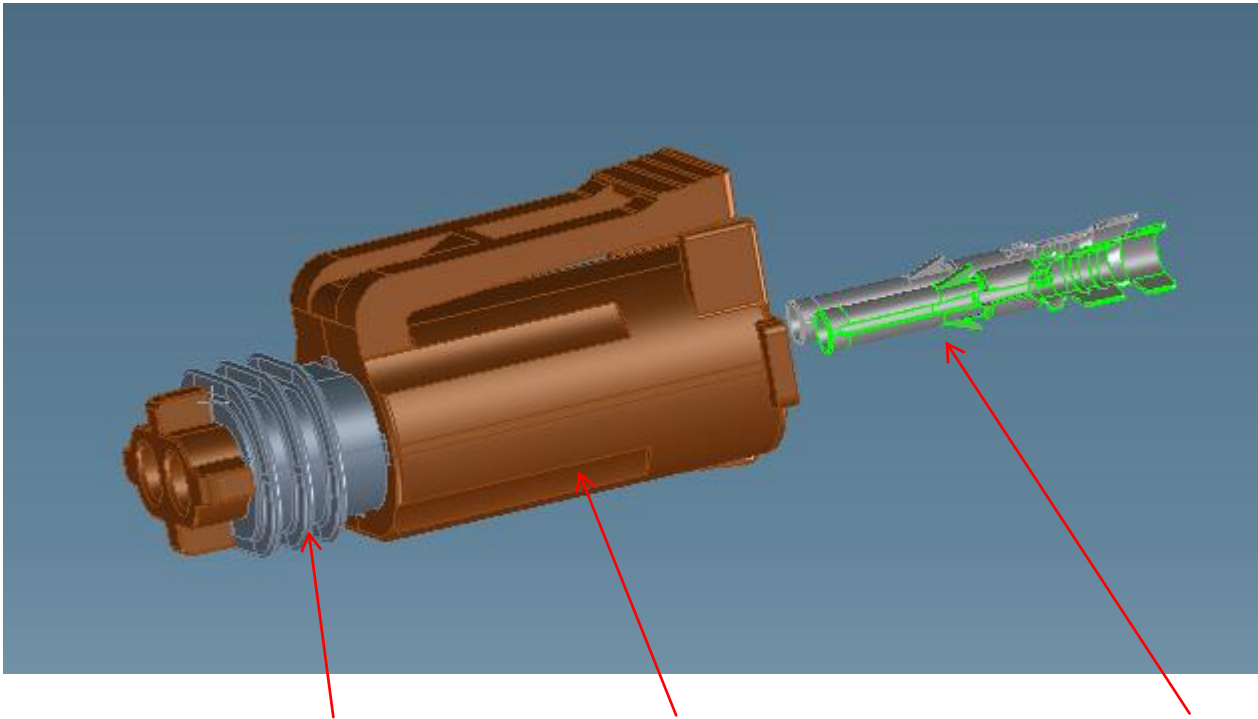

Ring seal

Receptacle housing

Female Terminals

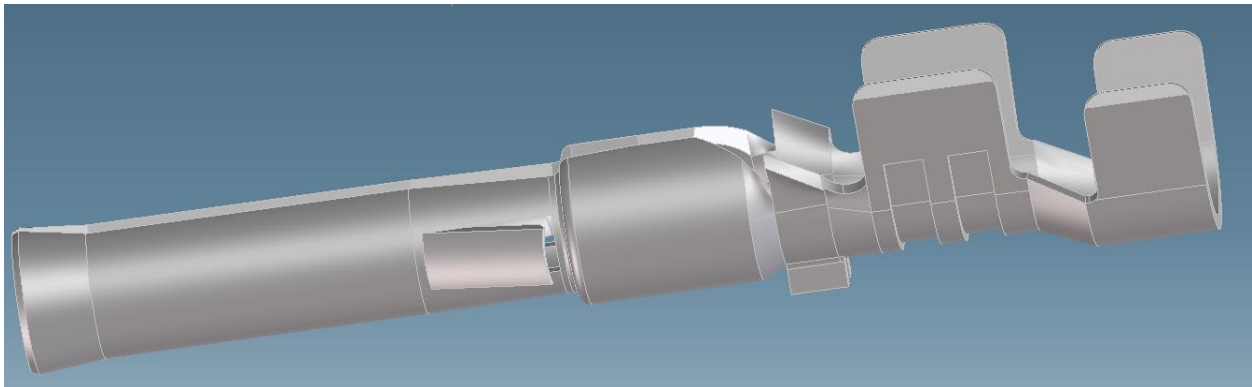

Female Terminal for Receptacle housing

REVISION: A2	ECR/ECN INFORMATION: EC No: 167947 DATE: 10/11/2017	TITLE: Application specification Valuseal sealed connector system	SHEET No. 4 of 16
DOCUMENT NUMBER: 1728770001-AS	CREATED / REVISED BY: Muttanna B	CHECKED BY: Muttanna B	APPROVED BY: ISHWAR G

Section 3: Plug connector Assembly

Male Terminal Insertion

1. Place the plug housing on the flat surface and hold by left hand as shown in figure 1.



Figure 1

2. Hold male terminal in vertical position with right hand.
Hold the terminal at a distance of 10-15 mm from insulation crimped area as shown in figure 2.

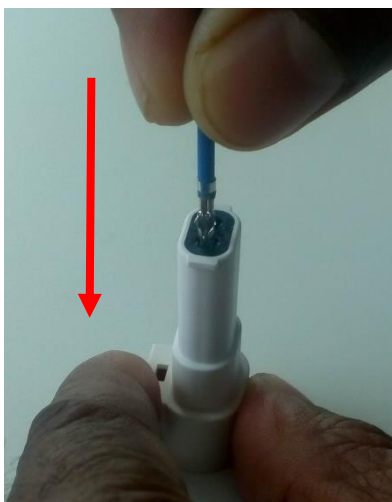

Figure 2



Figure 3

No orientation is needed during terminal assembly into housing (terminal can be inserted in 360° direction)

REVISION: A2	ECR/ECN INFORMATION: EC No: 167947 DATE: 10/11/2017	TITLE: Application specification Valuseal sealed connector system	SHEET No. 5 of 16
DOCUMENT NUMBER: 1728770001-AS	CREATED / REVISED BY: Muttanna B	CHECKED BY: Muttanna B	APPROVED BY: ISHWAR G

3. Insert the terminal gently into the housing as shown in figure 3. (Change the finger position after initial insertion to press the terminal further inside)
4. Push the terminal into the hole till the terminal reaches the dead end position (till it bottoms out) in the housing. Pull the terminal back gently to ensure that terminal is seated properly in the housing as shown in figure 4.

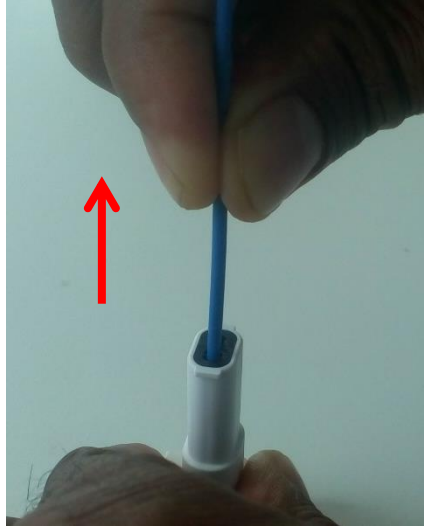

Figure 4

5. Insert terminals into both circuits and complete the insertion as shown in figure 5.



Figure 5

6. Reverse the assembled housing and carry out the visual inspection for terminal position, skiving etc...

REVISION: A2	ECR/ECN INFORMATION: EC No: 167947 DATE: 10/11/2017	TITLE: Application specification Valuseal sealed connector system	SHEET No. 6 of 16
DOCUMENT NUMBER: 1728770001-AS	CREATED / REVISED BY: Muttanna B	CHECKED BY: Muttanna B	APPROVED BY: ISHWAR G

Section 4: Receptacle connector Assembly

Female Terminal Insertion

1. Place the receptacle housing on the flat surface and hold by left hand as shown in figure 6.



Figure 6

2. Hold female terminal in vertical position with right hand.
Hold the terminal at a distance of 10-15 mm from insulation crimped area per figure 7.

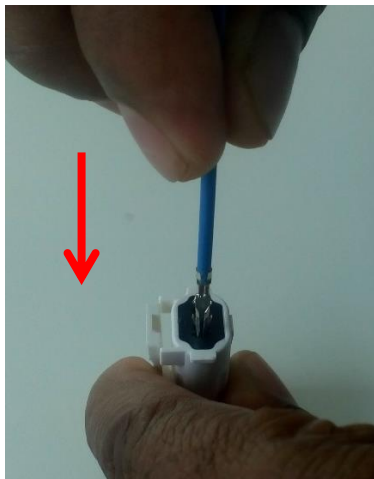

Figure 7

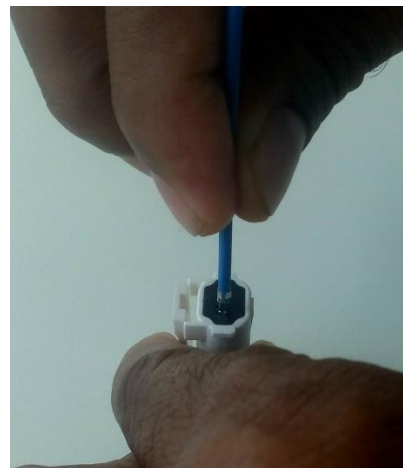

Figure 8

REVISION: A2	ECR/ECN INFORMATION: EC No: 167947 DATE: 10/11/2017	TITLE: Application specification Valuseal sealed connector system	SHEET No. 7 of 16
DOCUMENT NUMBER: 1728770001-AS	CREATED / REVISED BY: Muttanna B	CHECKED BY: Muttanna B	APPROVED BY: ISHWAR G

3. Insert the terminal gently into the housing as shown figure 8. Push gently inside and align to the internal hole manually in case of any stub due to bend in insertion.
 No terminal orientation is needed to the assembly (terminal can be inserted in 360° direction)
 (Change the finger position after initial insertion to press the terminal further inside)

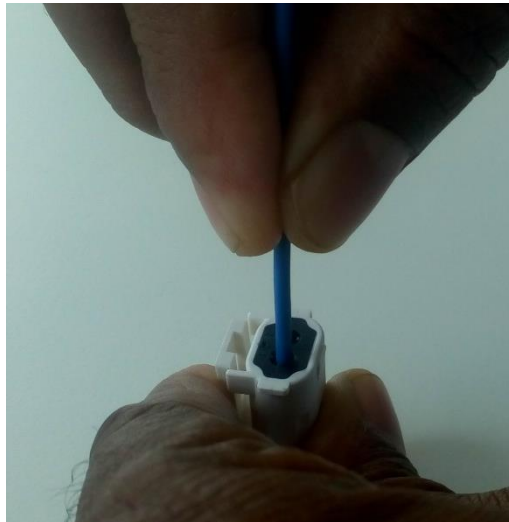

Figure 9

4. Push the terminal into the hole till the terminal reaches the dead end position in the housing as shown in figure 9. Pull the terminal back gently to ensure that terminal is seated properly in the housing as shown in figure 10.

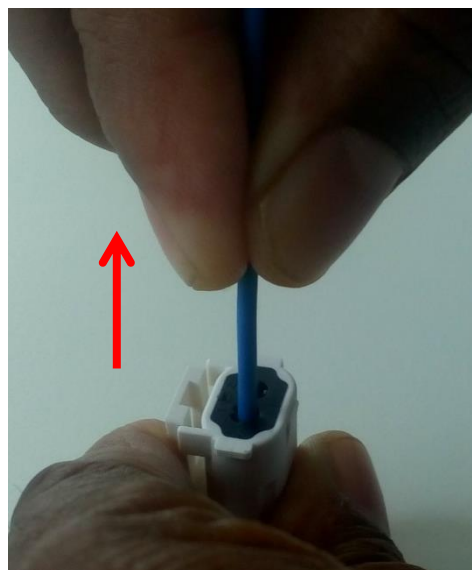

Figure 10

REVISION:	ECR/ECN INFORMATION:	TITLE:		SHEET No.
A2	EC No: 167947 DATE: 10/11/2017	Application specification Valuseal sealed connector system		8 of 16
DOCUMENT NUMBER:	CREATED / REVISED BY:	CHECKED BY:	APPROVED BY:	
1728770001-AS	Muttanna B	Muttanna B	ISHWAR G	

5. Insert terminals into both circuits and complete the insertion as shown in figure 11.



Figure 11

6. Reverse the assembled housing and carry out the visual inspection for terminal position, skiving etc...

Section 5: Cavity plug installation

- Place the plug/receptacle housing on the flat surface as shown in figure 12.
Hold cavity plug in vertical position with right hand & align the cavity plug into the housing hole as shown in figure 13.



Figure 12

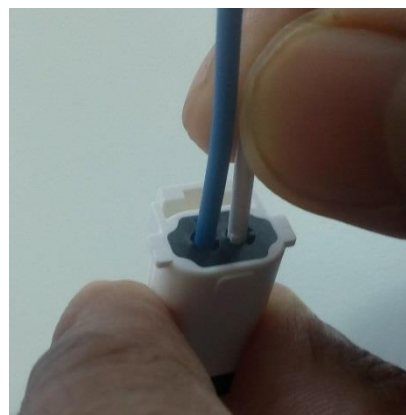

Figure 13

REVISION: A2	ECR/ECN INFORMATION: EC No: 167947 DATE: 10/11/2017	TITLE: Application specification Valuseal sealed connector system	SHEET No. 9 of 16
DOCUMENT NUMBER: 1728770001-AS	CREATED / REVISED BY: Muttanna B	CHECKED BY: Muttanna B	APPROVED BY: ISHWAR G

2. Press the cavity plug into the housing slot till the plug fits into its position.

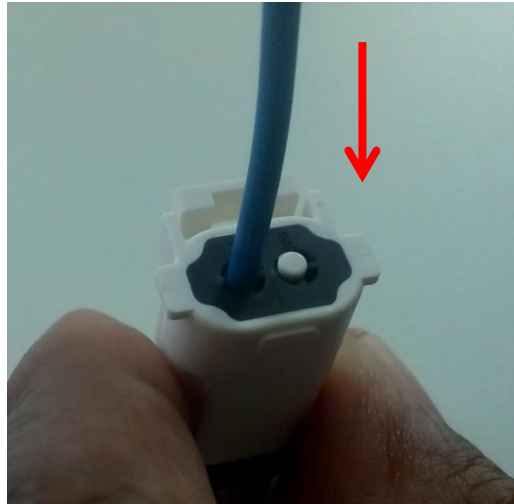

Figure 14

3. Above procedure to be followed wherever void positions are identified. Cavity plug insertion procedure is same for both plug and receptacle housing.

Section 6: WTW Connector Assembly

1. Hold the plug connector assembly and receptacle connector assembly as shown in figure 15. Align connector system latch features and begin mating process along the same axis.

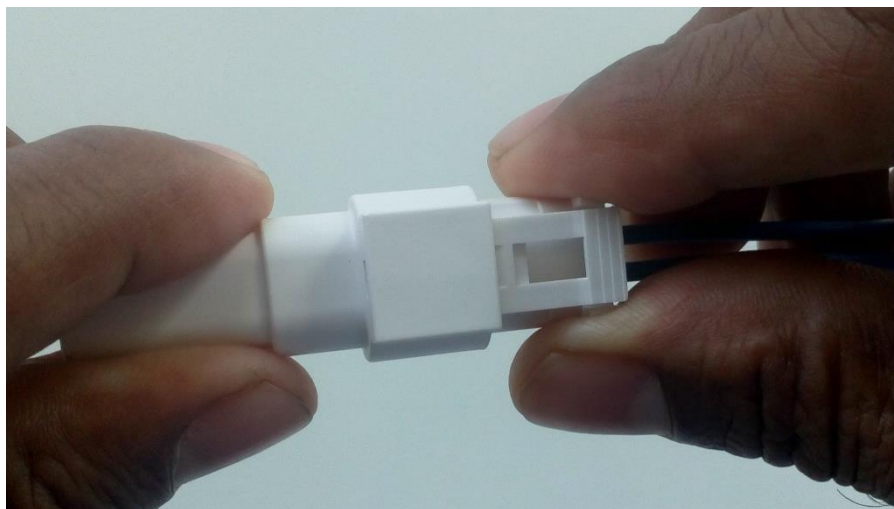

Figure 15

REVISION:	ECR/ECN INFORMATION:	TITLE:		SHEET No.
A2	EC No: 167947 DATE: 10/11/2017	Application specification Valuseal sealed connector system		10 of 16
DOCUMENT NUMBER:	CREATED / REVISED BY:	CHECKED BY:	APPROVED BY:	
1728770001-AS	Muttanna B	Muttanna B	ISHWAR G	
TEMPLATE FILENAME: APPLICATION_SPEC[SIZE_A4](V.2).DOC				

2. Press the receptacle housing latch until the latch locks (observe for “CLICK” sound)

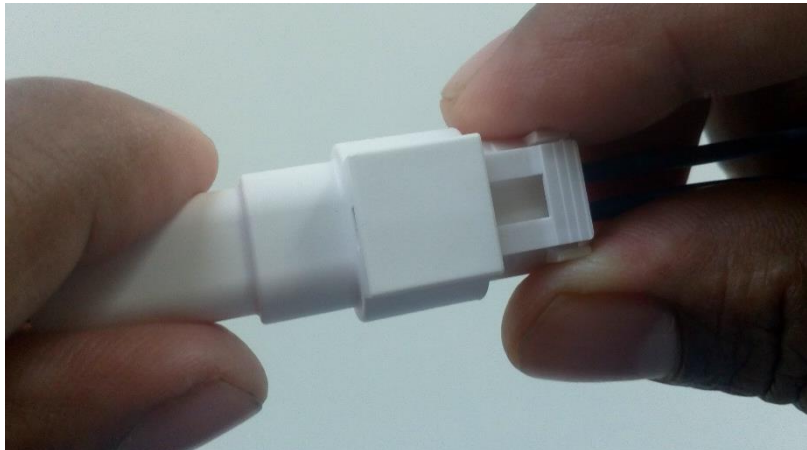

Figure 16

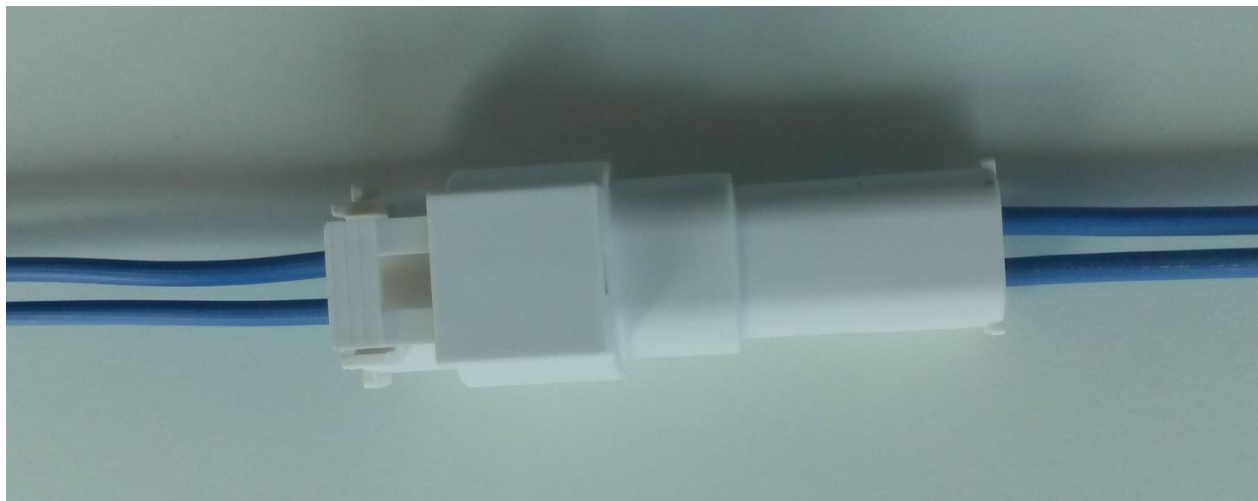

Figure 17

REVISION: A2	ECR/ECN INFORMATION: EC No: 167947 DATE: 10/11/2017	TITLE: Application specification Valuseal sealed connector system	SHEET No. 11 of 16
DOCUMENT NUMBER: 1728770001-AS	CREATED / REVISED BY: Muttanna B	CHECKED BY: Muttanna B	APPROVED BY: ISHWAR G

Section 7: Service instructions

A. Connector unmating instructions

1. Press the latch lever on receptacle assembly to disengage the latch and pull the plug assembly as shown in figure 18 and figure 19.

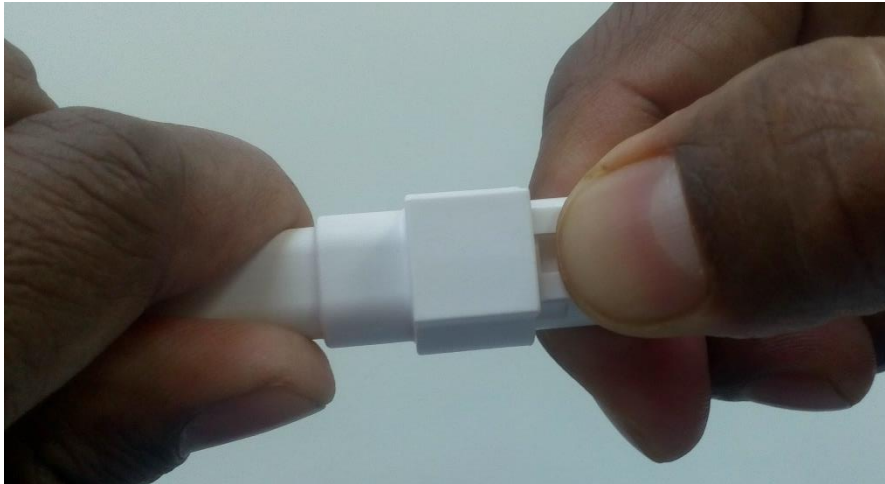

Figure 18

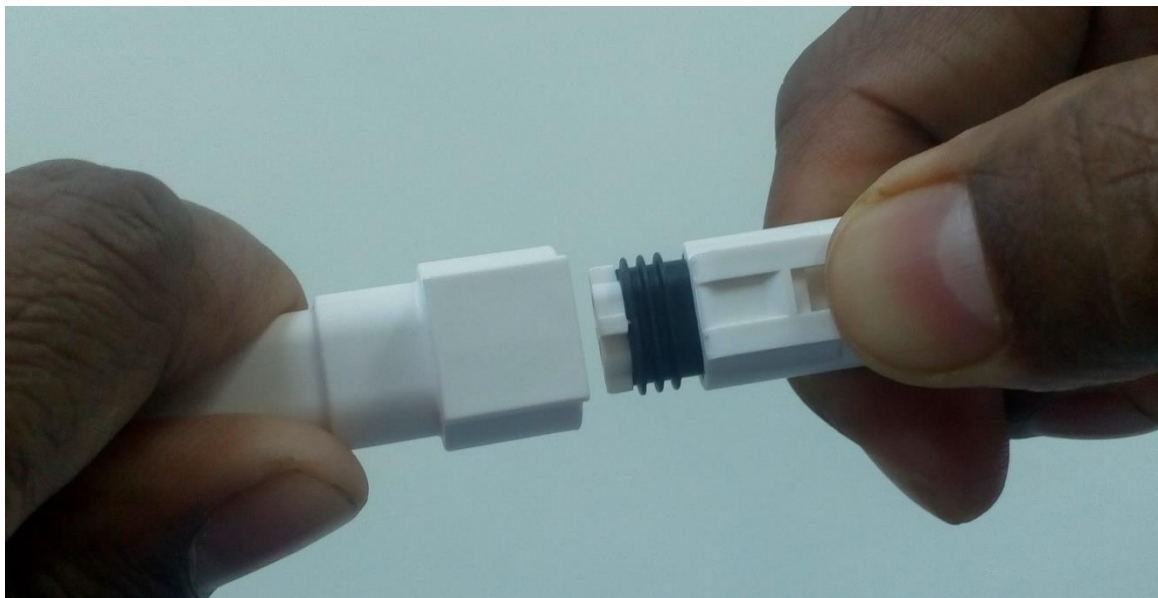

Figure 19

REVISION: A2	ECR/ECN INFORMATION: EC No: 167947 DATE: 10/11/2017	TITLE: Application specification Valuseal sealed connector system	SHEET No. 12 of 16
DOCUMENT NUMBER: 1728770001-AS	CREATED / REVISED BY: Muttanna B	CHECKED BY: Muttanna B	APPROVED BY: ISHWAR G
<small>TEMPLATE FILENAME: APPLICATION_SPEC\SIZE_A4\ (V.2).DOC</small>			

B. Male Terminal removal

- Using the extractor tool # 11030002, insert the extractor tool into the male terminal to be serviced.



- Push extractor tool straight down gently and press the Extraction Tool around the male terminal in 4 directions (as shown in the above pictures) the locking tab collapses from both the side. This motion will release the locking tabs. Pull the terminal gently by supporting the finger at the bottom face of connector.

Pull the terminal gently until the front portion of the terminal protrudes from connector bottom face as shown in below figure 20



Figure 20

- Extracted terminal should be removed from the housing and replace with new crimp terminal in same circuit.

REVISION: A2	ECR/ECN INFORMATION: EC No: 167947 DATE: 10/11/2017	TITLE: Application specification Valuseal sealed connector system	SHEET No. 13 of 16
DOCUMENT NUMBER: 1728770001-AS	CREATED / REVISED BY: Muttanna B	CHECKED BY: Muttanna B	APPROVED BY: ISHWAR G

C. Female Terminal removal

- Using the extractor tool # 11030002, insert the extractor tool into the male terminal to be serviced.



- Push extractor tool straight down gently and apply pressure to release locking finger. This motion will release the locking finger. Pull the terminal gently by supporting the finger at the bottom face of connector. Pull the terminal gently until the front portion of the terminal protrudes from connector bottom face as shown in figure 21



Figure 21

- Extracted terminal should be removed from the housing and replace with new crimp terminal in same circuit.

REVISION: A2	ECR/ECN INFORMATION: EC No: 167947 DATE: 10/11/2017	TITLE: Application specification Valuseal sealed connector system	SHEET No. 14 of 16
DOCUMENT NUMBER: 1728770001-AS	CREATED / REVISED BY: Muttanna B	CHECKED BY: Muttanna B	APPROVED BY: ISHWAR G

D. Cavity/Void plug removal

1. Using the extractor tool # 11030002, insert the extractor tool into the cavity/void plug to be serviced.
2. Push extractor tool straight down gently and apply pressure to release locking steps in cavity plug. Pull the Cavity / Void plug gently by supporting the finger at the bottom face of connector. Pull the cavity plug gently until the front portion of the cavity plug protrudes from connector bottom face as shown in figure 22 & 23.



Figure 22



Figure 23

3. Cavity plug removal / Extraction procedure is same for both plug and receptacle housing.

REVISION: A2	ECR/ECN INFORMATION: EC No: 167947 DATE: 10/11/2017	TITLE: Application specification Valuseal sealed connector system	SHEET No. 15 of 16
DOCUMENT NUMBER: 1728770001-AS	CREATED / REVISED BY: Muttanna B	CHECKED BY: Muttanna B	APPROVED BY: ISHWAR G

Section 8: Connector/Cable Clamping

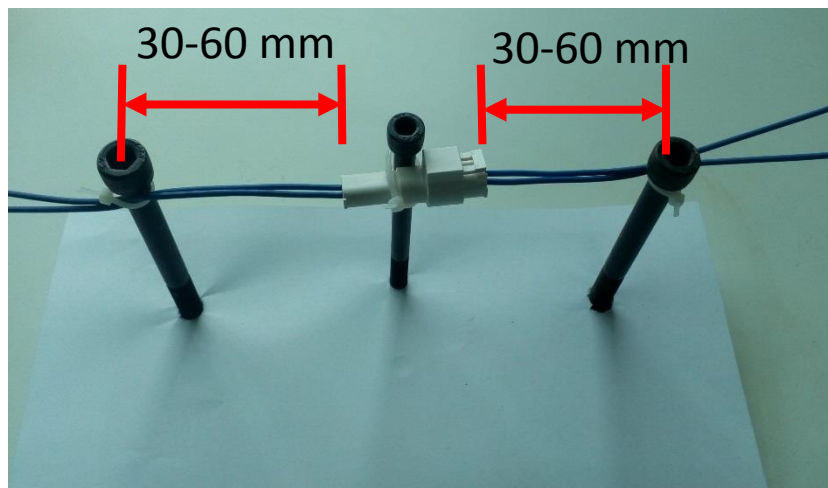

Figure 22

It is recommended to tie the cables (both side) at a distance of approximately 30-60 mm from the housing surface and cable should be straight to avoid the strain at sealing area per the figure 22.

Section 9: General application notes

Appearance:

- Parts conform to class "C" requirements of cosmetic specification PS-45499-002

REVISION: A2	ECR/ECN INFORMATION: EC No: 167947 DATE: 10/11/2017	TITLE: Application specification Valuseal sealed connector system	SHEET No. 16 of 16
DOCUMENT NUMBER: 1728770001-AS	CREATED / REVISED BY: Muttanna B	CHECKED BY: Muttanna B	APPROVED BY: ISHWAR G